

HAND PALLET TRUCK

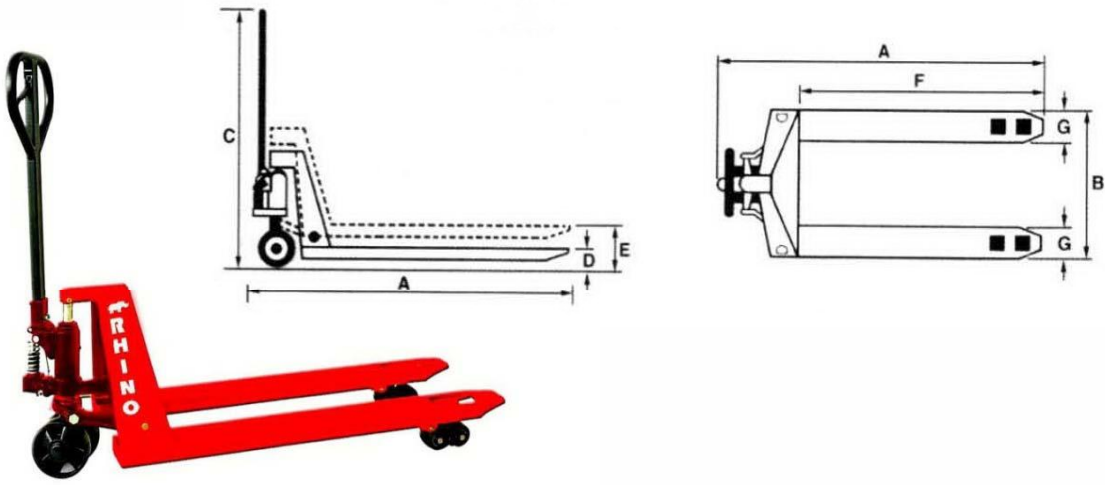

- Rugged construction and high quality hydraulic system with relief valve to protect overloading.
- Pump piston and piston lifting rod are chromium-plated for long life.
- Three positions control level for different functions i.e. upper, neutral and lower.
- Durable polyurethane wheels with ball bearings for easy moving.
- Minimum turning radius.

| TECHNICAL DATA | | | MODEL |
|---------------------|-----|-----|------------|
| | | | RPT-302 |
| Max. Load capacity | kg. | | 3000 |
| Overall length | A | mm. | 1580 |
| Overall width | B | mm. | 680 |
| Overall height | C | mm. | 1203 |
| Lowered fork height | D | mm. | 85 |
| Raised fork height | E | mm. | 195 |
| Fork length | F | mm. | 1220 |
| Fork width | G | mm. | 153 |
| Front wheel | | mm. | Ø 80 x 70 |
| Rear wheel | | mm. | Ø 180 x 50 |
| Total weight | kg. | | 102 |

SPECIFICATION IS SUBJECT TO CHANGE WITHOUT NOTICE.



Certificate Number: TH0000000M